

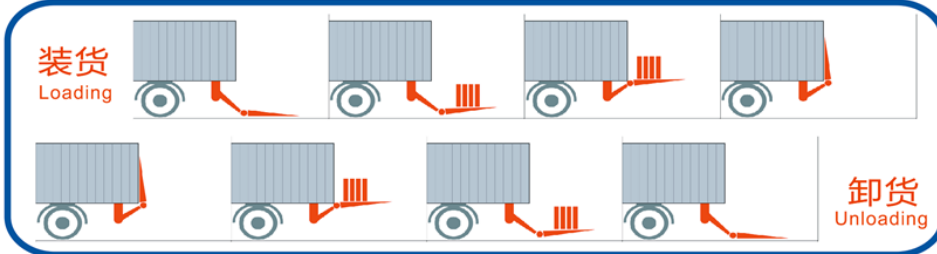

产品特点：
Products Feature

- 1 The core components are widely adopted the imported technology from England, Italy, U.S. All the main components are using the first-class brand at home and abroad.
- 2 The hydraulic cylinders use leakproof structure style which is our independent designed patent. It can drastically improve the products' reliability and stability.
- 3 More than 80% material use the high strength steel sheet (LG600XT, yield strength 650MPa). The structure is lighter and the strength is higher.
- 4 Bigger adjustment angle. It's more adapt to different road situation and working condition;
- 5 Less welded parts. The lifting arm structure is cut from the one-piece entity plank. It can make the structure strength and reliability stronger.
- 6 Further optimizing the hydraulic system, control system. The pipeline, circuit and connection are with integrated technology. The systems are simpler, more stable, more convenient to installation and maintenance.



型号 MODEL	板面尺寸 Plate size (mm)	额定载重 Rated loading capacity (kg)	最大举升高度 Max lifting height (mm)	系统压力 System pressure (MPa)	工作电压 Voltage (V)	平均升降速度 Average speed of lifting and falling (mm/s)	整机质量 Weight (kg)
SKX-08/065A	1600 * 1300	800	650	16	12/24	70	195
SKX-10/105A	1800 * 1650	1000	1050	16	12/24	80	280
SKX-10/155A	2300 * 1800	1500	1550	16	12/24	80	300
SKX-15/155A	2300 * 1800	2000	1550	16	12/24	80	350
SKX-20/155AB	2400 * 1800	2000	1550	16	12/24	80	410

安装定位尺寸主要为图示A、B、D、E、F五个参数

Installing and positioning dimensions are mainly the A, B, D, E, F graphic parameter.

型号 MODEL	A (MM)		B (MM)		D (MM)	E (MM)	F (MM)	大梁宽 (mm)	
	Min	Max	Min	Max	Max	Max	Max	Max	Max
SKX-08/065A	150	220	300	450	350	650	150	450	
SKX-10/105A	300	470	565	728	580	1050	180	750	
SKX-15/155A	400	700	830	1040	850	1550	200	750	
SKX-20/155A	400	700	830	1040	850	1550	200	800	
SKX-20/155AB	400	700	830	1040	850	1550	200	800	

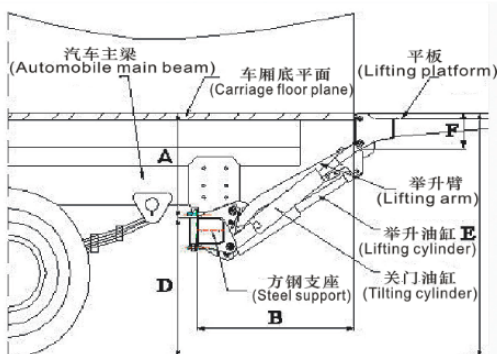

凯璇工程有限公司

SKX Engineering Pte Ltd

Address: Blk 9 Defu Lane 10, #01-502 Singapore 539190

Telephone: +65 6287 1873 Fax: +65 6280 1958

Email: sales@kaixuanengrg.com URL: www.kaixuanengrg.com

GST/Company Reg.: 200919393G

